

# Weller®

## OPERATING INSTRUCTIONS

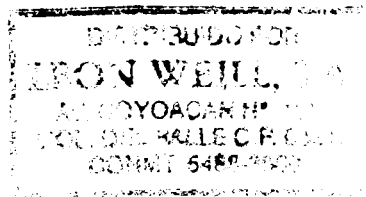

# EC1002S ELECTRONIC SOLDERING STATION

# MODEL EC1002S ELECTRONIC SOLDERING STATION

## OPERATING INSTRUCTIONS

Unpack unit carefully. Place spring and funnel in slot in top of tool stand. Attach tool stand to either side of the power unit, if desired. Fill reservoir with water and wet sponge, distilled water is preferred. Insert tool in holder and connect tool plug to receptacle on power unit; rotate plug housing to lock plug into receptacle. Insert line cord plug into properly grounded AC receptacle and turn station on. Set temperature control knob to desired tip temperature (approach desired temperature by turning CCW). Wait 30 seconds. Remove tool from holder and tin tip with solder. Unit is now ready for use.

Always use the lowest temperature that will handle the load you are soldering. The Weller® electronic control provides maximum power to the heated load even when set to the lowest temperature; therefore, there is no need to use high temperature to handle heavy soldering loads. By using lower temperatures and properly selecting tip styles, sensitive components will be protected from heat damage.

**WARNING: Do not remove ground prong from line cord plug. Removal may cause tip temperature control to be erratic.**

## AVAILABLE MODELS AND HAND PIECES

PRODUCT	DESCRIPTION
EC1002S-0	Power unit only, 120V 60 Hz, °F dial markings
EC1002S-0D	Power unit only, 230V 50/60 Hz, °C dial markings
EC1002S-1	Power unit, 120V 60Hz, °F dial markings, EC1201A tool with ETA tip and tool stand
EC1002S-1D	Power unit, 230V 50/60Hz, °C dial markings, EC1201A tool with ETA tip and tool stand
EC1002S-2	Power unit, 120V 60Hz, °F dial markings, EC1302A tool with EPH101 tip and tool stand
EC1002S-2D	Power unit, 230V 50/60Hz, °C dial markings, EC1302A tool with EPH101 tip and tool stand
EC1002S-3	Power unit, 120V 60Hz, °F dial markings, EC1503A tool with EMA tip and tool stand
EC1002S-3D	Power unit, 230V 50/60Hz, °C dial markings, EC1503A tool with EMA tip and tool stand
EC1201A	40 watt Soldering Tool w/ETA Tip
EC1302A	20 watt Soldering Tool w/EPH101 Tip
EC1503A	42 watt Soldering Tool w/EMA Tip

## SPECIFICATIONS

1. Power Input: 120VAC  $\pm 10\%$ , 60Hz, (230VAC  $\pm 10\%$ , 50/60 Hz), 60 watts
2. Power unit output voltage: isolated 24VAC @ 2.1 amperes.
3. Size: 4.5" x 5.9" x 3.6"
4. Line Cord: 3 wire, UL recognized.
5. Tip temperature control range: 350°F to 850°F (175°C to 455°C).
6. Control setting resolution: 10°F (5°C).
7. Stability:  $\pm 10^\circ\text{F}$  ( $\pm 6^\circ\text{C}$ ) per MIL-STD-2000.
8. Absolute accuracy: Average tip temperature is calibrated to  $\pm 9^\circ\text{F}$  ( $\pm 5^\circ\text{C}$ ) at idle with no load.
9. Ambient temperature range: 60°F to 110°F (16°C to 44°C).
10. Housing made with Electrostatic Protective Material as required in MIL-B-81705.
11. Housing passes Static Decay test per Federal Test Method Standard No. 101, method 4046.
12. Weller® ESD tools comply with DOD-HDBK-263.
13. EC1002S units are UL listed and meet DOD-STD-2000, MIL-STD-2000, MIL-S-45743, W-S-6536, W-S-570, DOD-STD-1686.

## MATERIALS NEEDED FOR CALIBRATION CHECK

The EC1201A, EC1302A and EC1503A soldering tools use high precision platinum RTD temperature sensors and therefore require no calibration and are interchangeable. The power unit is factory calibrated; but can easily be checked using a WC1000 Calibration Reference Unit and re-calibrated if required.

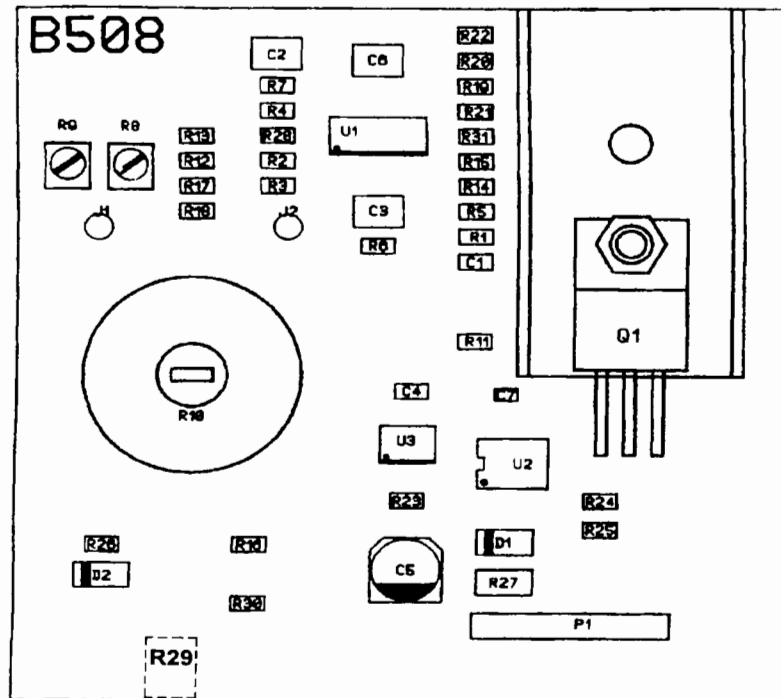

CIRCUIT BOARD LAYOUT

## CALIBRATION CHECK

1. Disconnect soldering tool from the tool receptacle on the power unit and connect to the receptacle on the WC1000 Calibration Reference Unit. Connect the WC1000 to the tool receptacle on the power unit and select resistor "B".

**CAUTION: The power unit should not be turned above 350°F (175°C) for more than 1 minute with the tool connected to the WC1000 to prevent damage to the tool heating element.**

2. Rotate temperature set knob fully CCW and turn power unit on. Indicator lamps on WC1000 should be out. Allow 30 minute warm-up before continuing.
3. Rotate temperature set knob fully CW, indicator lamps should be full on.
4. Rotate temperature set knob CCW until indicator lamps stop flashing. Temperature set should equal 730°F ±10 (390°C ±6).
5. Select resistor "A" on the WC1000 Calibration Reference Unit.
6. Rotate temperature set knob CCW until indicator lamps stop flashing. Temperature set should equal 375°F ±10 (190°C ±6).
7. If calibration is out of tolerance, perform the re-calibration procedure.

## TIP TEMPERATURE CALIBRATION PROCEDURE

1. Monitor the tip temperature with a 30 gauge thermocouple resistance welded to the center of the wetted area, tinning should be removed before welding. K-111, K-121 and K-131 temperature test kits are recommended; see Replacement Parts and Accessories Section.
2. Set the temperature set knob to the desired temperature and allow the tip temperature to stabilize.
3. Adjust R29, accessible through the hole in the station bottom directly below the temperature set knob, until the indicated tip temperature matches the set temperature.

## RE-CALIBRATION PROCEDURE

Because the power unit must be disassembled to gain access to the calibration adjustments, this procedure is not recommended unless the Calibration Check is performed and re-calibration is indicated.

**CAUTION: Disconnect the power cord before disassembling power unit.**

1. Remove 4 rubber feet and screws under the feet, remove top cover from station.
2. Note how front panel is engaged with base and then lift front panel free of base.
3. Set temperature set knob fully CW and then CCW to 730°F (390°C). Carefully remove knob by sliding off of pot shaft without rotating shaft. Check that R29 (see figure ) is centered.
4. Connect the WC1000 Calibration Reference Unit to the tool receptacle on the power unit and select resistor "B". Do not connect tool to the WC1000 at this time!
5. Connect power cord and turn power unit on. Allow 30 minutes to warm-up before continuing.

**CAUTION: The power unit should not be turned above 350°F (175°C) for more than 1 minute with the tool connected to the WC1000 to prevent damage to the tool heating element.**

6. Connect tool to the WC1000 receptacle as a load. Adjust R8 (see figure) until indicator lamps stop flashing.
7. Set temperature set knob CCW to 375°F (190°C), select resistor "A" on the WC1000 and adjust R9 (see figure) until indicator lamps stop flashing.
8. Turn power unit off and dis-connect power cord and WC1000.
9. Position front panel on base as noted above.
10. Perform Calibration Check to verify calibration.
11. Install top cover on station and replace 4 screws and rubber feet.

## TROUBLESHOOTING GUIDE

**WARNING:** AC line voltage is present inside power unit even when power switch is off. Refer service to qualified personnel.

**NOTE:** Access to internal parts may be gained by removing four rubber feet, four screws under feet and top case.

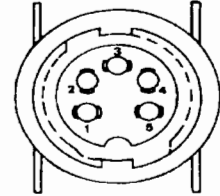

## TOOL DOES NOT HEAT

With line cord unplugged and power switch on, check for about 21 ohms at line cord blades (55 ohms for 230V unit).

- Check fuse, located on bottom of case - replace if required. Use slow blow fuse - 0.6A for 120V, 0.3A for 220V.
- Check power switch - replace if defective.
- Check line cord - repair or replace if defective.
- Check transformer primary - replace transformer if defective.

With line cord plugged in and power switch on, check for 24VAC  $\pm 10\%$  between pins #1 and #4 of tool receptacle.

- Check transformer secondary for 24VAC  $\pm 10\%$  - replace transformer if defective.
- Check wiring to printed circuit board assembly - repair or replace if defective.
- Replace printed circuit board assembly.

Check wiring from tool receptacle to printed circuit board.

- Repair or replace if defective.

Replace soldering tool with known good tool and recheck.

- Troubleshoot soldering tool using guide in tool tech sheet.

Replace printed circuit board assembly.

## **TOOL OVERHEATING**

Replace soldering tool with known good tool and recheck.

- Troubleshoot soldering tool using guide in tool tech sheet.

Replace printed circuit board assembly in station.

## **TIP TEMPERATURE TESTING ERRORS**

**NOTE:** Tip temperature testing must be done using 30 gauge thermocouple wire resistance welded to the center of the wetted area on the tip, tinning should be removed before welding. Other methods, or heavier thermocouple wire, will cause errors. K-111, K-121 and K-131 temperature test kits are available; see Replacement Parts and Accessories Section.

Replace soldering tool with known good tool and recheck tip temperature.

- Troubleshoot soldering tool using guide in tool tech sheet.

Calibrate station according to Tip Temperature Calibration Procedure.

## **HIGH TIP VOLTAGE**

Replace soldering tool with known good tool and recheck tip temperature.

- Troubleshoot soldering tool using guide in tool tech sheet.

Check for continuity from pin #5 of tool receptacle to line cord ground pin.

- Check wiring from tool receptacle to line cord ground pin - repair if defective.



## **CUSTOMER SERVICES**

Should your EC1002S require repair or adjustment it may be sent to the following address:

**Cooper Hand Tools Division  
Cheraw Plant  
815 State Road  
Cheraw, SC 29520  
ATTN: Repair Department  
(803) 537-5167**

# REPLACEMENT PARTS AND ACCESSORIES

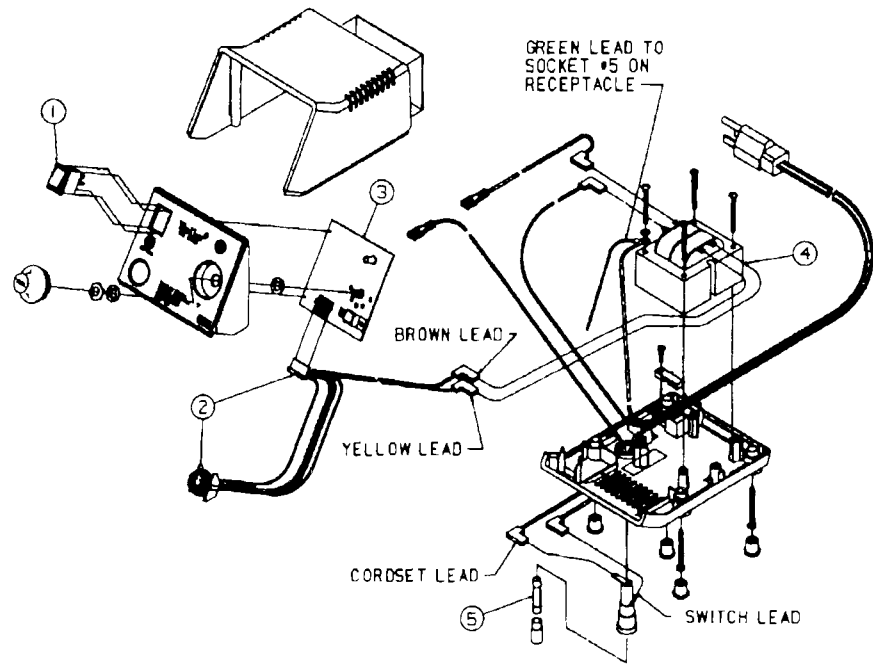

KEY NO.	PART NO.	DESCRIPTION
1	SW110	Power Switch
2	EC270	Receptacle and Wire Harness
3	EC271	Circuit Board Assembly
4	TR234	Power Transformer, 120VAC, EC1002S-0
5	FP3	Fuse, .6 AMP Slo Blo
Not Shown	TC205	Sponge
Not Shown	DS200K	Desoldering Adapter Kit
Not Shown	TC204	Spring and Funnel for EC1201A Tool
Not Shown	IHF225EC	Spring and Funnel for EC1302A Tool
Not Shown	EC254	Spring and Funnel for EC1503A Tool
Not Shown	EC1201AP	EC1201A Tool with Stand
Not Shown	EC1302AP	EC1302A Tool with Stand
Not Shown	EC1503AP	EC1503A Tool with Stand
Not Shown	SF60	Tool Funnel for SMT Tips
Not Shown	SMTA	Surface Mount Tip Adapter for EC1201A Tool
Not Shown	SMTA-EM	Surface Mount Tip Adapter for EC1503A Tool
Not Shown	WC1000	Calibration Unit
Not Shown	WA2000	Soldering Tool Analyzer
Not Shown	WPB1	Weller® Polishing Bar
Not Shown	K-111	Temperature Test Kit for EC1201A Tool
Not Shown	K-121	Temperature Test Kit for EC1302A Tool
Not Shown	K-131	Temperature Test Kit for EC1503A Tool

Cooper Hand Tools Div.  
Weller Products  
Lufkin Road  
Apex, NC 27502  
Tel: (919) 362-7511  
Fax: (919) 387-2460

Cooper Tools GmbH  
Carl-Benz-Str. 3  
D-74354  
Besigheim, Germany  
Tel: (07143) 580-0  
Fax: (07143) 580-108

Cooper Tools S.A.  
B.P. 63 ZA des Petits Carreaux  
4, avenue des Coquelicots  
F-94382 Bonneuil-sur Marne Cedex  
Tel: (1) 43.39.70.39  
Fax: (1) 43.77.94.24

Cooper Industries Italia S.p.A.  
Cooper Tools Division  
Via Lazio 65  
I-20094 Buccinasco (MI)  
Tel: (02) 45700053 (r.a.)  
Fax: (02) 48843706

Cooper Tools Pty.  
519 Nurigong Street  
Albury, N.S.W. 2640  
Australia  
Tel: 61-60-215511  
Fax: 61-60-217403

  
**COOPER**  
CooperTools