

JOIN US ON THE INTERNET...
VISIT OUR WEB SITE AT
<http://www.spectronic.com>

SPECTRONIC[®] 20+ SERIES Spectrophotometers

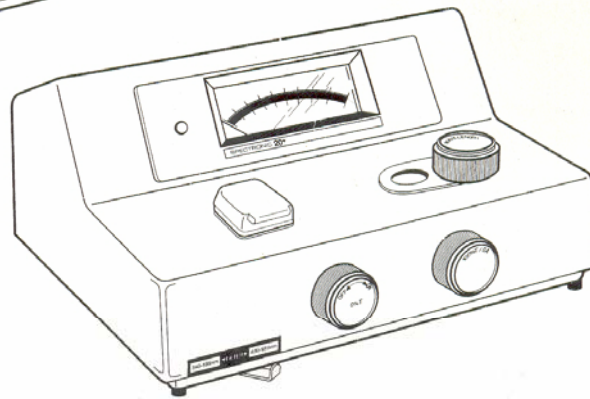
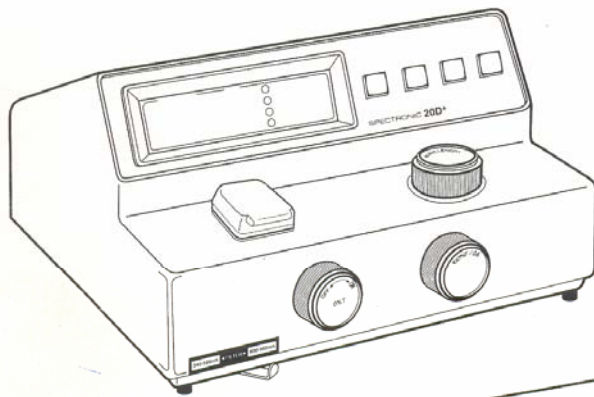

OPERATOR'S
MANUAL

 **Spectronic**
Instruments, Inc.

NOTE

This operator's manual contains information and instructions for the Spectronic Instruments SPECTRONIC® 20+ and 20D+ spectrophotometers that were believed accurate at the time this manual was written. However, as part of Spectronic Instruments' on-going program of product development, the specifications and operating instructions for these spectrophotometers may be modified or changed as needed. Spectronic Instruments reserves the right to change such operating instructions and specifications. Under no circumstances shall Spectronic Instruments be obligated to notify purchasers of any future changes in either this operator's manual or any other instructions or specifications relating to the SPECTRONIC 20 series spectrophotometers, nor shall Spectronic Instruments be liable in any way for its failure to notify purchasers of such changes.

FCC COMPLIANCE STATEMENT FOR U.S.A. USERS

This equipment generates, uses, and can radiate radio frequency energy, and if not installed and used in accordance with the instruction manual, may cause interference to radio communications. It has been tested and found to comply with the limits for Class A computing device pursuant to Subpart J of Part 15 of FCC Rules, which are designed to provide reasonable protection against such interference when operated in a commercial environment. Operation of this equipment in a residential area is likely to cause interference in which case the user at his own expense will be required to take whatever measures may be required to correct the interference.

Copyright © 1995, Spectronic Instruments, Incorporated.
All rights reserved.

SPECTRONIC is a registered trademark of Spectronic Instruments, Incorporated.
All other brand and product names are trademarks or registered trademarks
of their respective companies.

NEW PRODUCT WARRANTY

Spectronic Instruments instrumentation and related accessories are warranted against defects in material and workmanship for a period of one (1) year from the date of delivery. The SPECTRONIC® 20+ series of spectrophotometers is warranted against defects in material and workmanship for a period of three (3) years from the date of delivery.

This warranty covers all parts (except those specified below) and labor, and applies only to equipment which has been installed and operated in accordance with the operator's instruction manual and which has been serviced only by authorized Spectronic Instruments dealers or service personnel. This warranty does not apply to equipment and accessories that have been modified or tampered with in any way, misused, or damaged by accident, neglect, or conditions beyond Spectronic Instruments' control.

This warranty does not apply to lamps, glassware, and similar expendable components. However, such parts and components may be warranted by their manufacturer.

Spectronic Instruments is not responsible under this warranty for loss in operating performance due to environmental conditions.

THIS WARRANTY IS IN LIEU OF ALL WARRANTIES EXPRESSED, IMPLIED, OR STATUTORY, INCLUDING, BUT NOT LIMITED TO, WARRANTIES OF FITNESS FOR A PARTICULAR PURPOSE OR MERCHANTABILITY OR OTHERWISE, and states Spectronic Instruments' entire and exclusive liability and the Customer's exclusive remedy for any claim in connection with the sale or furnishing of services, goods, or parts, their design, suitability for use, installation, or operations. Spectronic Instruments will in no event be liable for any direct, indirect, special, or consequential damages, whatsoever, including loss of goodwill, whether grounded in tort (including negligence), strict liability or contract, and Spectronic Instruments' liability under no circumstances will exceed the contract price for the goods and/or services for which liability is claimed.

Contents

Section 1 - Introduction	1-1
Operating features of the SPECTRONIC® 20+ spectrophotometer .	1-5
Operating features of the SPECTRONIC® 20D+ spectrophotometer	1-5
Section 2 - Installation & Operating Procedures	2-1
Environment	2-1
Setup/Installation	2-1
Technique	2-2
Sample Measurements	2-2
Printing	2-4
Remote operation	2-5
Section 3 - Maintenance	3-1
Lamp Replacement	3-1
Cleaning the sample compartment	3-1
Wavelength Calibration Check	3-2
Photometric linearity check	3-3
Replacing phototubes	3-4
Service Procedure	3-5
Troubleshooting	3-5
Section 4 - Accessories	4-1
Appendix A - Choosing a Readout Mode	A-1
Transmittance Mode	A-1
Absorbance Mode	A-1
Concentration Mode	A-1
Concentration-Factor-Check Feature	A-2
Appendix B - Optical Diagram	B-1

Section 1 - Introduction

The SPECTRONIC® 20 series of spectrophotometers is one of the most widely used laboratory instruments. Over the years, the series has been improved and now includes the SPECTRONIC® 20⁺ and the SPECTRONIC® 20D⁺.

This section describes these two latest instruments and their basic operating features. The table below

summarizes the specifications for the two current models in the SPECTRONIC® 20 series.

Operational procedures for the SPECTRONIC® 20 and 20D spectrophotometers are included in this manual.

Table 1-1 Specifications for SPECTRONIC® 20⁺ and SPECTRONIC® 20D⁺ Spectrophotometers

SPECIFICATIONS	SPECTRONIC® 20 ⁺	SPECTRONIC® 20D ⁺
Spectral slit width	20nm	
Wavelength range	340 to 950nm	
Wavelength accuracy	±2.5nm near 525nm	
Display	Meter 5½" mirrored scale linear %T, non-linear A	LED %T, A, C, Factor, Wavelength
Photometric range	0 to 100%T 0 to 2 A	0 to 200%T 0 to 1.95A 0 to 1999C (0.1 to 1000 Factor)
Photometric accuracy	±2%T	
Photometric noise	±0.5%T	
Stray radiant energy	0.5%T* from 340nm to 950nm	
Accessory output	1.0 VDC nominal at 100%T	1.0 VDC nominal at 100%T RS-232C serial I/O port
Power requirements	100/115V, 50/60Hz; 220/240V, 50/60Hz	
Dimensions	16.25" W (41.3cm) x 8.5" H (21.6cm) x 13.5" D (34.3cm)	
Weight	Net: 18lbs. (8.2kg)	

* When measured with appropriate accessory filter installed (Accessory Filter Kit 333129)

Your instrument package includes:

- SPECTRONIC® 20⁺ (Cat. No. 333182) or SPECTRONIC® 20D⁺ (Cat. No. 333183) spectrophotometer
- SPECTRONIC® 20⁺ Series Spectrophotometers Operator's Manual (Cat. No. 333182-10001)
- Box of 12 test tube cuvettes (Cat. No. 331780)
- Dust cover (Cat. No. 332961-149)
- Lamp Gripper (Cat. No. 333182-117)
- ½" Adapter (Cat. No. 333178)
- 1/16" Allen wrench (Cat. No. 332260-174) for interchanging test-tube adapters

The SPECTRONIC® 20⁺ spectrophotometer (Cat. Nos. 333182-000, 333182-02, 333182-04, 333182-05 or 333182-07), shown in Figure 1-1, is a single-beam meter spectrophotometer with a wavelength range of 340 nm to 950 nm. The nominal spectral slit width of 20 nm is constant over the entire range.

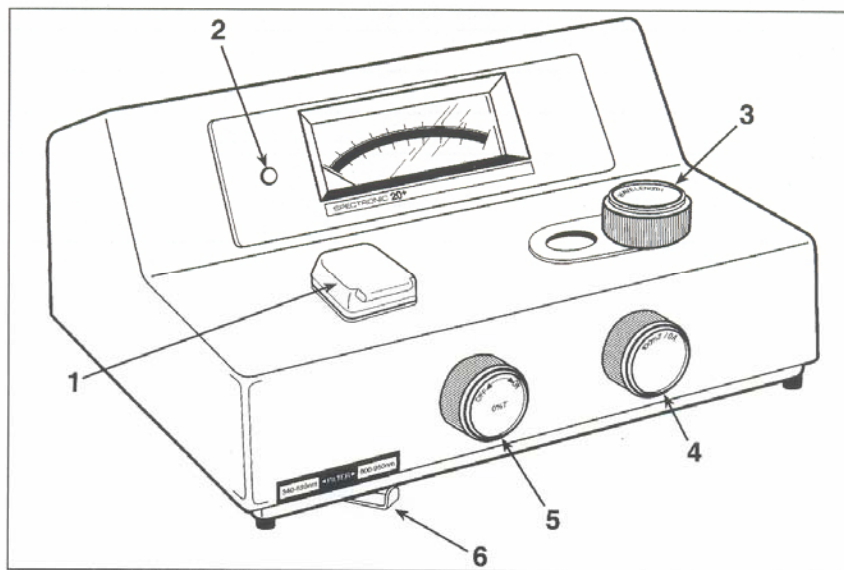

Figure 1-1 SPECTRONIC 20⁺ spectrophotometer

KEY

1. Sample compartment
2. Pilot lamp
3. Wavelength control
4. Transmittance/Absorbance control (100%T/0A)
5. Power switch/Zero control
6. Filter lever

The SPECTRONIC[®] 20D⁺ spectrophotometer (Cat. Nos. 333183-000, 333183-02, 333183-04, 333183-05 or 333183-07), shown in Figure 1-2, is a single-beam digital spectrophotometer with a

wavelength range of 340 nm to 950 nm. The nominal spectral slit width of 20 nm is constant over the entire range.

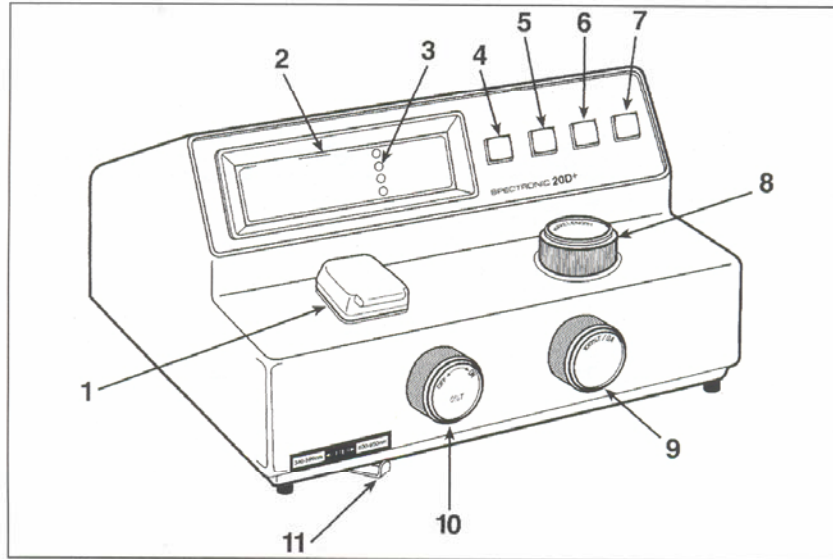

Figure 1-2 SPECTRONIC 20D⁺ spectrophotometer

KEY

- | | |
|-----------------------|--|
| 1. Sample compartment | 7. Print |
| 2. Digital readout | 8. Wavelength control |
| 3. Mode indicators | 9. Transmittance/Absorbance control (100%T/0A) |
| 4. Mode selection | 10. Power switch/Zero Control |
| 5. Decrease | 11. Filter lever |
| 6. Increase | |

The main features on the underside of the instrument are shown in Figure 1-3.

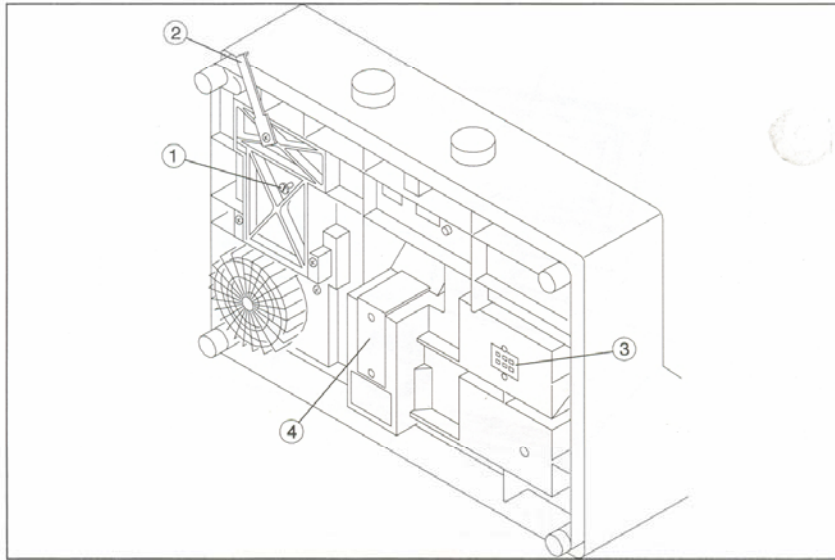

Figure 1-3 Bottom view of SPECTRONIC 20⁺ or 20D⁺

KEY

1. Filter lever
2. Lamp access door with thumbscrew
3. Analog output jack/Serial I/O port
4. Line voltage switch (under this plate) [international models only]

Operating features of the SPECTRONIC[®] 20⁺ spectrophotometer

The main controls for routine operation are the Power Switch/Zero Control, Wavelength Control, Filter Lever and Transmittance/Absorbance Control.

Power Switch / Zero Control

The ON-OFF main power switch is operated by the Power Switch/Zero Control knob. The Zero Control knob is used to set the display to a 0%T readout when the sample compartment is empty and the adapter cover is closed.

Wavelength Control

The Wavelength Control selects the desired analytical wavelength of the instrument. The selected wavelength is indicated on the wavelength scale in the window next to the knob. Red numbers indicate that the 600-950nm filter should be used; black numbers indicate that the 340-599nm filter should be used. All gradations are in 5-nm intervals.

Filter Lever

This control selects the filter to be used for the measurement:

- Red is used for measurements from 600 to 950nm.
- Black is used for measurements from 340 to 599nm.

Meter

Readings are taken directly from the meter in either transmittance or absorbance.

Transmittance / Absorbance Control

This control sets the display to 100%T (0.0A) when a cuvette containing a blank reference solution is inserted in the sample compartment. **It must be**

reset whenever the analytical wavelength has been changed. When operating at a fixed wavelength for an extended period of time, check the 100%T (0.0A) readout and readjust if necessary.

Analog Output Jack

This jack is used to connect an analog recorder to the instrument (see Figure 1-3). The analog output signal level is fixed at approximately 1 VDC at 100%T. This output is not adjustable.

The signals on each pin are listed below:

- 1 Analog output
- 2 Analog ground
- 3 Analog ground
- 4 Meter (+)
- 5 Analog output
- 6 Meter (-)

Operating features of the SPECTRONIC[®] 20D⁺ spectrophotometer

The main controls for routine operation are the Power Switch/Zero Control, Wavelength Control, Filter Lever, Transmittance/Absorbance Control, the MODE selector and Factor Adjust controls.

The accessory Analog Output/Serial I/O port is located on the underside of the instrument, as shown in Figure 1-3.

Power Switch / Zero Control

The ON-OFF main power switch is operated by the Power Switch/Zero Control knob. The Zero Control knob is used to set the display to a 0%T readout when the sample compartment is empty and the adapter cover is closed.

Wavelength Control

The Wavelength Control selects the desired analytical wavelength of the instrument. The selected wavelength appears on the left side of the LED display. The Filter Lever should be set to the proper filter for the wavelength setting.

Filter Lever

This control selects the filter to be used for the measurement:

- Red is used for measurements from 600 to 950nm.
- Black is used for measurements from 340 to 599nm.

Digital Readout

The Digital Readout displays wavelength and data readings. The four LED status indicators, next to the labels TRANSMITTANCE, ABSORBANCE, CONCENTRATION and FACTOR indicate the MODE currently active.

Transmittance / Absorbance Control

This control sets the display to 100%T (0.0A) when a cuvette containing a blank reference solution is inserted in the sample compartment. **It must be reset whenever the analytical wavelength has been changed.** When operating at a fixed wavelength for an extended period of time, check the 100%T (0.0A) readout and readjust if necessary.

MODE Select

This control selects the TRANSMITTANCE, ABSORBANCE, CONCENTRATION or FACTOR mode.

Factor Adjust Controls

The pushbuttons labelled INCREASE and DECREASE are used in the CONCENTRATION and FACTOR modes. To set a lower CONCENTRATION or FACTOR value, press and hold down the DECREASE button until the desired value is displayed. To set a higher value, press and hold down the INCREASE button until the desired value is displayed.

Print

This pushbutton is used to send data to a serial printer connected to the output jack.

Analog Output / Serial I/O Port

Analog Output

This port is used to connect an analog recorder to the instrument. The analog output signal level is approximately 1 VDC at 100%T. This output is not adjustable.

Serial Port

The Serial Input/Output (I/O) Port is used to connect the instrument to the Accessory Printer (Cat. No. 335488) or to an external device, enabling the instrument to accept and execute any one of six commands sent from the device in RS-232-C format. The signals on each pin are listed below:

- 1 Analog output
- 2 Clear to send (CTS)
- 3 Ground
- 4 Transmit data (TXD)
- 5 Receive data (RXD)
- 6 Print

Refer to page 2-5 for remote operation and to Table 2-1 on page 2-1 for cabling requirements.

Section 2 - Installation & Operating Procedures

Environment

Make sure that your spectrophotometer is placed as far as possible from any strong magnetic or electrical fields, or any electrical apparatus that may generate high-frequency fields.

The instrument should be installed in an area that is free of dust, corrosive gases and severe vibrations.

In addition, there should be no obstructions that could hinder the flow of air under and around the instrument.

Setup/Installation

1. Select the appropriate glassware and adapters. For more information about glassware, adapters and cell holders, refer to Table 4-1 on page 4-1 and Table 4-2 on page 4-2.
2. If you are connecting the instrument to an Accessory Printer, computer or chart recorder, refer to Table 2-1 for information about cabling requirements.

Table 2-1 Cabling requirements for SPECTRONIC® 20 series of spectrophotometers

DEVICE	20 / 20*	20D	20D*
Analog Recorder	• 333174 - Patch Cord	• 333174 - Patch Cord	• 333174 - Patch Cord
Accessory Printer	Not available	<ul style="list-style-type: none"> • 333177 - Serial Interface Cable • 335488-1601 (included with Serial Printer 335488) 	• 333132 - Serial Interface Cable Kit
IBM PC XT	Not available	<ul style="list-style-type: none"> • 333177 - Serial Interface Cable • 335243 - Null Modem Cable <p>OR</p> <ul style="list-style-type: none"> • 333132 - Serial Interface Cable Kit 	• 333132 - Serial Interface Cable Kit
IBM PC AT	Not available	<ul style="list-style-type: none"> • 333177 - Serial Interface Cable • 335243 - Null Modem Cable • 345002-111 - Adapter Cable <p>OR</p> <ul style="list-style-type: none"> • 333132 - Serial Interface Cable Kit 	• 333132 - Serial Interface Cable Kit

3. If you are using either a SPECTRONIC[®] 20 or 20D, refer to Table 2-2 for information on filters and phototubes that must be installed for accurate results.

Table 2-2 Phototube options (SPECTRONIC[®] 20 and 20D only)

Range	Phototube	Filter
	Cat. No.	Cat. No.
340 to 600 nm	332971**	None required
600 to 950 nm	332972	332918*
400 to 700 nm	332989	332992*

*Or use appropriate filter from Accessory Filter Kit (Cat. No. 333128)

**Included with instrument

4. Plug in the instrument.
5. Turn on the Power Switch/Zero Control and allow the instrument to warm up for at least 15 minutes.

Technique

Successful use of your spectrophotometer depends on the consistent use of correct laboratory procedures and analytical techniques. To minimize problems, follow these simple rules:

- Keep all solutions free of bubbles.
- Make sure that all sample holders are at least half full.
- Use the same cuvette for both sample and blank measurements.
- Use square cuvettes (Cat. No. 331709) with Holder (Cat. No. 333176) for greater accuracy.
- Make sure that the mark (fiducial line) on the test tube aligns with the mark on the adapter toward the front of the instrument.
- During extended operation at a fixed wavelength, check from time to time for 100%T drift. Possible causes of drift are listed in Table 3-1 in the *Maintenance* section.
- Use clean test tubes and do not touch the test tubes below the fiducial line.

Sample Measurements

Once your instrument has been set up properly and has warmed up for at least 15 minutes, you can begin taking measurements.

SPECTRONIC[®] 20 and 20⁺

Notes:

- To read the meter properly, align the needle with its reflection in the mirror.
- It is important to insert the blank and reset the meter to 100%T every time the wavelength is changed.

Tip: The basic steps for taking measurements are highlighted in **bold text** in the following instructions.

1. **Turn on** the SPECTRONIC[®] 20⁺ by turning the Power Switch/Zero Control (knob on the left side of instrument) clockwise. Allow the spectrophotometer to warm up for at least 15 minutes to stabilize.
2. After the warmup period, **set the desired wavelength** with the Wavelength Control Knob.
3. **Set the filter lever** to the appropriate position for the selected wavelength (not required for SPECTRONIC[®] 20).
4. **Adjust the meter to 0%T** with the Power Switch/Zero Control (knob on the front left side of instrument). Make sure the sample compartment is empty and the cover is closed.
5. Fill a clean cell with water (or blank solution) and wipe the cell with a tissue to remove liquid droplets, dust and fingerprints.
6. **Place the cell in the sample compartment** and align the guide mark on the cell with the guide mark at the front of the sample compartment. Press the cell firmly into the sample compartment and close the lid.
7. **Adjust the meter to 100%T** with the Transmittance/Absorbance Control (knob on the front right side of instrument).
8. Remove the cell from the sample compartment and empty the water.
9. Rinse the cell twice with small volumes of the solution to be measured and fill it with the solution.

10. Wipe the cell with a tissue and **insert the cell into the sample compartment**. Align the guide marks and close the lid.
11. **Read the appropriate value (%T or A)** from the meter.
12. Remove the cell from the sample compartment and repeat steps 9 through 11 for any remaining sample solutions.
13. When all measurements are completed, turn off the spectrophotometer by turning the Power Switch/Zero Control counterclockwise until it clicks.

SPECTRONIC[®] 20D and 20D⁺

Notes:

• Flashing display

A flashing display indicates that the reading is out of range and the 100%T/0A control must be adjusted. This adjustment controls an optical occluder which regulates the amount of light passing through the sample.

In %T mode:

A reading greater than 200%T will cause the display to flash.

- If the flashing reading is -1999, turn the 100%T/0A control clockwise until the display operates normally.

- If the flashing reading is +1999, turn the 100%T/0A control counterclockwise until the display operates normally.

In absorbance mode:

A reading greater than 2A will cause the display to flash.

- If the flashing reading is -1999, turn the 100%T/0A control counterclockwise until the display operates normally.

- If the flashing reading is +1999, turn the 100%T/0A control clockwise until the display operates normally.

It may require several complete turns of the 100%T control to return to the proper range.

• Change in wavelength

It is important to insert the blank and reset the display to 100%T or 0.0A every time the wavelength is changed.

Tip: The basic steps for taking measurements are highlighted in **bold text** in the following instructions.

Transmittance and Absorbance

1. **Turn on** the instrument by turning the Power Switch (knob on the left side of instrument) clockwise. Allow the spectrophotometer to warm up for at least 15 minutes to stabilize.
2. After the warmup period, **set the desired wavelength** with the Wavelength Control Knob.
3. **Set the filter lever** to the appropriate position for the selected wavelength (not required for SPECTRONIC[®] 20D).
4. Adjust the display to 0%T with the Zero Control (knob on the front left side of the instrument). Make sure that the sample compartment is empty and the cover is closed.
5. **Set the display mode** to TRANSMITTANCE or ABSORBANCE by pressing the MODE control key until the appropriate LED is lit.
6. Fill a clean cell with water (or another blank solution) and wipe the cell with a tissue to remove liquid droplets, dust and fingerprints.
7. **Place the cell in the sample compartment** and align the guide mark on the cell with the guide mark at the front of the sample compartment. Press the cell firmly into the sample compartment and close the lid.
8. **Adjust the display to 100%T or 0.0A** with the Transmittance/Absorbance Control (knob on the right side of instrument).
9. Remove the cell from the sample compartment and empty the water.
10. Rinse the cell twice with small volumes of the solution to be measured and fill it with the solution.

11. Wipe the cell with a tissue and **insert the cell into the sample compartment**. Align the guide marks and close the lid.
12. **Read the appropriate value (%T or A)** from the display.
13. Remove the cell from the sample compartment and repeat steps 10 through 12 for any remaining sample solutions.
14. When all measurements are completed, turn off the spectrophotometer by turning the Power Switch counterclockwise until it clicks.

*Concentration measurements using
CONCENTRATION mode*

1. Follow steps 1 through 9 of the **Transmittance and Absorbance** procedure (using the absorbance mode).
2. Rinse the cell twice with small volumes of the standard solution of *known* concentration and fill the cell with the solution. Wipe the cell with a tissue and **insert the cell in the sample compartment**. Align the guide marks and close the lid.
3. **Press the MODE control key** until the LED beside "concentration" is lit.
4. **Press the INCREASE or DECREASE key** until the displayed value matches the concentration of the standard solution.

Note: Limits are 0 to 1999.

5. To determine the factor, press the MODE control key until the LED beside the "Factor" is lit. Read and record the factor value. Press the MODE control key until the LED beside "Concentration" is lit.
6. Remove the standard solution and rinse and fill the cell with the sample solution of unknown concentration. Wipe the cell with a tissue and **insert the cell in the sample compartment**.
7. **Read the concentration** of the sample directly from the display.

8. Remove the cell from the sample compartment and repeat steps 6 and 7 for each of the samples.
9. When all measurements are completed, turn off the spectrophotometer by turning the Power Switch counterclockwise until it clicks.

Concentration measurements using FACTOR mode

Note: Refer to Appendix A for more information about the FACTOR mode.

1. Determine the factor value by following steps 1 through 4 of the procedure for "Concentration mode" above.
2. **Press the MODE control key** until the LED beside "factor" is lit.
3. **Press the INCREASE or DECREASE key** until the desired factor is displayed (a value between 0.100 and 1000).
4. **Press the MODE control key** to select the CONCENTRATION mode.
5. Rinse and fill the cell with the sample solution of unknown concentration. Wipe the cell with a tissue and **insert the cell in the sample compartment**.
6. **Read the concentration** of the sample directly from the display.
7. Remove the cell from the sample compartment and repeat steps 5 and 6 for each of the samples.
8. When all measurements are completed, turn off the spectrophotometer by turning the Power Switch counterclockwise until it clicks.

Printing [SPECTRONIC[®] 20D and 20D⁺ only]

Normally, the spectrophotometer is in the print mode when it is first turned on and operates at a rate of 1200 baud. A range of other transmission rates, from 110 to 9600 baud, may also be accommodated.

To use the Accessory Printer:

1. Set the baud rate on the Accessory Printer to 1200 (Refer to the Accessory Printer Operator's Manual, Cat. No. 335488-10001).
2. Push the PRINT key for a printout.

Remote operation [SPECTRONIC® 20D and 20D* only]

Command set

An external device may send the commands listed in Table 2-5 to the SPECTRONIC® 20D and 20D* spectrophotometer. Table 2-4 lists conventions for serial I/O data.

Table 2-4 Serial I/O data conventions

Word length	8 data bits, 1 stop bit; most significant bit set to 0
Parity	None
Echo	None
Terminators	Ignores all carriage return or line feed characters sent by external device (except for CR in Auto Baud Rate mode). Transmits ASCII CR/LF after every data line.

Data format

Data from the instrument to a printer or other remote device is sent as shown in the following example:

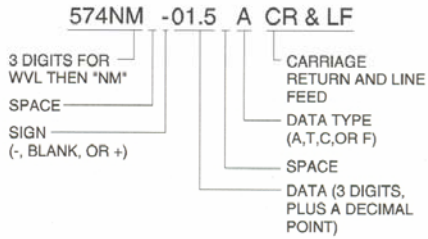

Table 2-5 Commands for remote operation of SPECTRONIC® 20D* spectrophotometers

Command	Function
P	Print
A	Set the data mode to absorbance
T	Set the data mode to transmittance
C	Set the data mode to concentration
F	Set the data mode to factor
CONTROL-X	Reset the spectrophotometer to initial power-up condition
E (or an ASCII carriage return, CR)	Set the spectrophotometer's baud rate to the rate used by a computer connected to the serial output port

Baud rate settings

Data is sent to the printer (or received from an external device) at a rate of 1200 baud if the instrument is turned on with the PRINT line "high" (at logic 1, greater than 2.0 VDC). Other baud rates may be selected when the spectrophotometer is connected to a computer. These rates include 110, 300, 1200, 2400, 4800 and 9600 baud.

If the spectrophotometer is turned on with the PRINT line "low" (logic 0, less than 0.8 VDC), it adjusts to the computer's baud rate upon receipt of either the letter "E" or a carriage return (CR) character from the computer.

Note:

- The PRINT line is normally "high." The PRINT line can be set "low" by pressing the PRINT button.
- For SPECTRONIC® 20D models, you can set the PRINT line "low" by pressing the pushbutton on the Serial Interface Cable (Cat. No. 333177) while turning on the spectrophotometer.

Section 3 - Maintenance

Because of the functional design and reliability of the SPECTRONIC® 20* and 20D* spectrophotometers, routine customer maintenance has been reduced to replacement of the 6.0-volt, 3.00-amperes source lamp (Cat. No. 333385). SPECTRONIC® 20 and 20D models also require replacement of the phototube (see Table 2-2).

Note: The source lamp has a nominal life of 250 hours.

The operator may also perform routine checks for wavelength calibration and photometric accuracy.

Lamp Replacement

1. Turn off and unplug the instrument.
2. Tilt up the unit and set on its back.
3. Loosen the thumbscrew on the lamp access door and open the door (see Figure 1-3).
4. Using finger pressure, press the lamp socket toward the mounting bracket (Figure 3-1).

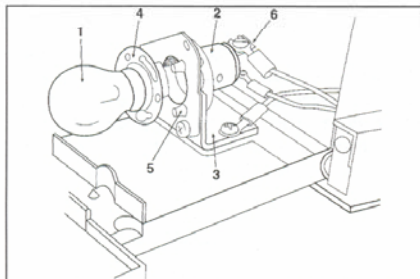

Figure 3-1 Lamp replacement

KEY

- | | |
|---------------------|------------------|
| 1. Lamp | 4. Lamp flange |
| 2. Lamp socket | 5. Locating pins |
| 3. Mounting bracket | 6. Terminals |

5. To avoid getting skin oils on the surface of the lamp, use the Lamp Gripper supplied with the instrument to grip the lamp. Push the lamp toward the lamp socket and rotate counterclockwise to remove it.
6. Install a new lamp by properly aligning the large openings in the lamp flange with the locating pins. Press the lamp and the lamp socket toward each other and rotate the lamp clockwise until secure.
7. Clean the lamp of fingerprints and oils, close the door and tighten securely. **This is essential for proper operation.**

Note:

- Do not push on the lamp socket terminals. This will inhibit the installation of a new lamp.

Cleaning the sample compartment

In the event a test tube breaks in the sample compartment, it is important to remove the glass and any spilled liquid as soon as possible.

1. Turn off and unplug the instrument.
2. Use protective equipment (safety goggles, gloves, lab coat, etc.).
3. Using tweezers, remove broken pieces of glass from the sample compartment.
4. While supporting the instrument, move it to the edge of the lab bench so that the lamp access door may be opened.
5. Loosen the lamp access door thumbscrew and carefully open the door. Spilled fluid may be present inside. Make sure to clean up all liquid that was spilled.
6. Reach inside the lamp compartment and remove any remaining glass.
7. Tip the instrument back on the lab bench and clean the sample compartment with an appropriate cleaning solvent.

8. Visually inspect the lamp, photodiode or phototube, and filters to determine if any liquid has spilled on them. Refer to Figure 3-2 or Figure 3-3.

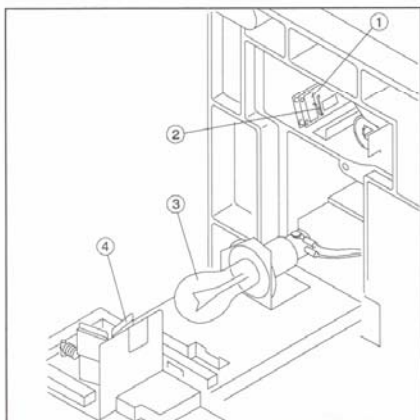

Figure 3-2 Location of photodiode

KEY

- | | |
|--------------------|-----------|
| 1. Photodiode | 3. Lamp |
| 2. Connection wire | 4. Filter |

9. Remove any liquid spilled on the lamp, filter, photodiode or phototube surfaces:
- **Lamp, filter and phototube surfaces:** Clean with a soft cloth or the softest area of a cotton swab and glass cleaner
 - **Photodiode:** The photodiode is easily damaged; cleaning should be performed by your Spectronic Instruments service organization. Clean the photodiode only if liquid is spilled on it. Use **very light pressure** with the softest area of a cotton swab dipped in high-grade isopropyl alcohol. **Do not touch the wire connected to the detector.**
10. Close the door and tighten the thumbscrew.
11. Check the calibration of the instrument using the procedures below or call your local Spectronic Instruments service organization, if necessary.

Wavelength Calibration Check

Under normal operating conditions, the SPECTRONIC[®] 20⁺ and 20D⁺ spectrophotometers should retain their wavelength accuracy indefinitely. If the instrument is subjected to a severe shock or other abuse, wavelength performance may be checked by one of three methods:

- Cobalt solution check
- Didymium filter from the Accessory Filter Kit (Cat. No. 333129)
- Wavelength Accuracy Test from SPECTRONIC[®] Standards (Cat. No. 333150)

An explanation of the cobalt solution check follows. Instructions on use of the didymium filter and SPECTRONIC[®] Standards are found in the user's manual for each accessory.

Cobalt solution check

To prepare a stock cobalt solution:

1. In a 1-liter volumetric flask, place 200 mL distilled water. Slowly and cautiously add 10 mL concentrated hydrochloric acid (ACS grade). Mix and make to volume with distilled water to obtain 1% hydrochloric acid solution.
2. In a 1-liter volumetric flask, place 22 to 23 gm cobalt chloride (CoCl₂, ACS grade). Dissolve in the 1% hydrochloric acid. Make to volume with 1% hydrochloric acid to obtain cobalt chloride stock solution.

To perform the cobalt solution check:

1. Turn on the Power Switch/Zero Control and allow the instrument to warm up for at least 15 minutes.
2. If you have a SPECTRONIC[®] 20D or 20D⁺, set the display mode to Transmittance.
3. With the sample compartment empty and the cover closed, adjust the Power Switch/Zero Control until the meter or display reads 0%T.
4. Set the Wavelength Control to 500 nm.
5. Set the Filter Lever to 340 - 599nm.

6. Insert the glassware filled with distilled water into the sample compartment and use the Transmittance/Absorbance Control to set the meter or display to 100%T.
7. Replace the distilled water with the cobalt chloride solution.
8. Insert the glassware filled with the cobalt chloride solution into the sample compartment.
9. Read %T on the meter or display.
10. Repeat steps 4 through 9 at 505, 510, 515 and 520 nm. The instrument is in proper calibration when minimum transmittance (maximum absorbance) occurs between 505 and 515 nm. The specific transmittance (or absorbance) values are unimportant.
4. Prepare 0.01N sulfuric acid diluent by adding 0.3mL of concentrated sulfuric acid to about 500mL of deionized or distilled water in a clean 1L volumetric flask. Fill to volume with deionized or distilled water.
5. Prepare a stock solution of potassium dichromate by weighing 0.500g of potassium dichromate (e.g., Fisher Certified A.C.S. potassium dichromate, formula weight 294.19) and dissolving it in about 400mL of 0.01N sulfuric acid solution in a 500mL volumetric flask. Fill to volume with 0.01N sulfuric acid solution. This is your stock 1.0g/L potassium dichromate solution.
6. Measure 2.5mL of the stock 1.0g/L potassium dichromate solution into a clean 100mL volumetric flask containing about 75mL 0.01N sulfuric acid solution. Fill to volume with 0.01N sulfuric acid solution. This is your 0.025g/L potassium dichromate solution.
7. Measure 5.0mL of the stock 1.0g/L potassium dichromate solution into a clean 100mL volumetric flask containing about 75mL 0.01N sulfuric acid solution. Fill to volume with 0.01N sulfuric acid solution. This is your 0.05g/L potassium dichromate solution.
8. Set the Wavelength Control to 350nm.
9. Set Filter Lever to 340 - 950nm.
10. Fill a 10mm pathlength rectangular cuvette with 0.01N sulfuric acid solution and place it in the sample compartment.
11. Set the readout of the instrument to 0A.
12. Fill the 10mm pathlength rectangular cuvette with 0.025g/L potassium dichromate solution, place it in the sample compartment and read the absorbance. You should expect to read 0.248A.
13. Fill the 10mm pathlength rectangular cuvette with 0.05g/L potassium dichromate solution, place it in the sample compartment and read the absorbance. You should expect to read 0.496A.

Wavelength calibration adjustment

If the wavelength accuracy is out of tolerance, refer to the *Service Procedure* section on page 3-5. Customer recalibration is not recommended.

Photometric linearity check

If the photometric linearity of the instrument is questionable, first check your analytical procedure and technique (see *Techniques* on page 2-2). If proper operation is still in doubt, use the Photometric Accuracy/Linearity Test from SPECTRONIC® Standards (Cat. No. 333150) to test and evaluate photometric performance of your instrument.

The alternate method below uses specially prepared potassium dichromate solutions.

1. Turn on the Power Switch/Zero Control and allow the instrument to warm up for at least 15 minutes.
2. Make sure that the sample compartment is empty and the cover is closed, then adjust the Power Switch/Zero Control until the display reads 0%T.
3. If you have a SPECTRONIC® 20D or 20D*, set the display mode to Absorbance.

Note: Values should be within 0.02A of the expected absorbance values, if the solutions have been prepared carefully.

Replacing phototubes (SPECTRONIC[®] 20 or 20D models only)

To change the phototube:

1. **Turn off and unplug the instrument.**
2. Tilt up the unit and set on its back.
3. Loosen the thumbscrew on the lamp access door (see Figure 1-3).
4. Remove the phototube using the plastic straps as an aid (see Figure 3-3).
5. Install the new phototube. If a filter is required, insert it into the holder on the inside of the door (see Figure 3-3). The tube and filter must be clean and free of fingerprints, (If necessary, use a lint-free tissue for cleaning.)
6. Close the door and securely fasten the thumbscrew. **This is essential for proper operation.**

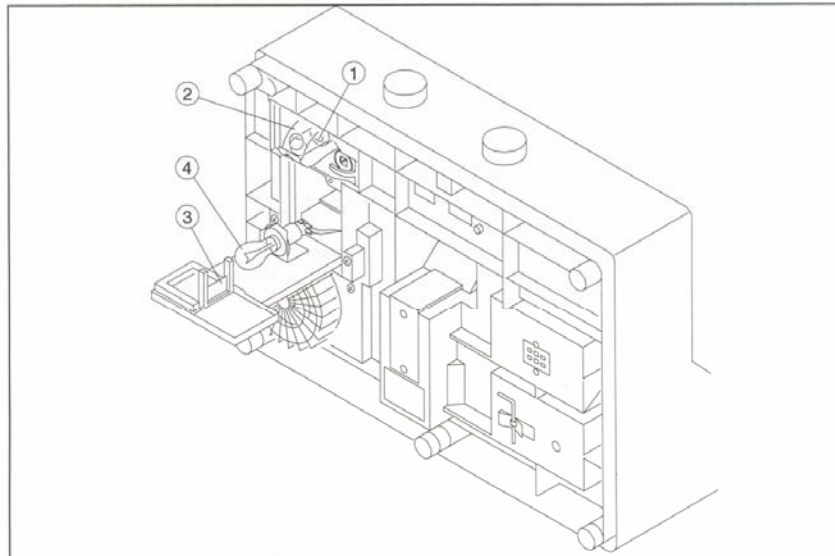

Figure 3-3 Lamp compartment for SPECTRONIC[®] 20 and 20D models

KEY

- | | |
|-------------------|------------------|
| 1. Phototube | 3. Filter holder |
| 2. Plastic straps | 4. Lamp |

Service Procedure

If the instrument develops a malfunction that cannot be corrected by operator maintenance, it may be serviced by your local Spectronic Instruments service organization.

- If you are in the U.S.A., contact Spectronic Instruments whether the instrument is still under warranty or it has expired.
- If you are outside the U.S.A., contact the distributor from whom you purchased the instrument whether the instrument is still under warranty or it has expired.

If it is necessary to ship the instrument:

1. Wrap the spectrophotometer in plastic, then pack carefully in a crush-resistant carton with at least three inches of shock absorbing material to prevent transit damage.

2. Include a detailed letter inside the shipping carton, fastened to the instrument, describing the trouble. Please include the name and phone number of the person or department head most familiar with the problem. This information enables service personnel to make required repairs promptly and at least expense.
3. In the United States, mark on the shipping container:
FIRST CLASS LETTER ENCLOSED
First class postage is required only on the letter. The carton is accepted at standard mail rates.

Troubleshooting

Table 3-1, *Operator's Troubleshooting Guide*, outlines some diagnostic techniques that may help you isolate the cause of a problem.

Table 3-1 Operator's troubleshooting guide

Problem	Possible Cause	Remedy
1. Instrument does not function	a. Power line cord not connected to outlet.	Plug in power line cord.
	b. Dead power outlet.	Try a different power outlet.
	c. Internal fuse blown.	Refer to service manual or service center.
	d. Defective electronic component.	Refer to service manual or service center.
2. Meter/Display does not zero.	a. Sample compartment cover not closed.	Close cover.
	b. Lamp access door not tightly closed.	Close door and retighten thumbscrew.
	c. Phototube defective.	Replace as required.
	d. Defective electronic component.	Refer to service manual or service center.
3. Readings are drifting or incorrect.	a. Poor sampling technique.	<ul style="list-style-type: none"> • Eliminate bubbles or particles in solution. • Set 100%T on appropriate blank solution.
	b. Filter selection lever is in wrong position.	Set filter lever to proper position.
	c. Fumes from sample.	Remove sample immediately after analysis.
	d. Excessive line voltage variation.	Check voltage and grounding.
	e. Wrong line voltage setting (international models only).	Reset Line Voltage Selection Switch.
	f. Source lamp defective.	Replace with new lamp.
	g. Phototube defective.	Replace as required.
	h. Defective electronic component.	Refer to service manual or service center.

Table 3-1 (continued)

Problem	Possible Cause	Remedy
4. Cannot set 100%T (0.0A), or display flashes.	a. 100%T not properly set.	Set 100%T with blank solution in the sample compartment and cover closed. Several turns of the 100%T control may be necessary.
	b. Filter selection lever in wrong position.	Set filter lever to proper position.
	c. 0%T not properly set (all models except SPECTRONIC® 20D*).	Set 0%T with the sample compartment empty and the cover closed.
	d. Occluder closed.	Install test tube in sample compartment.
	e. Sample holder not fully inserted into adapter.	Insert fully.
	f. Source lamp weak or burned out.	Replace with new lamp.
	g. Wrong line voltage setting (international models only).	Reset Line Voltage Selection Switch.
	h. Phototube weak.	Replace as required.
	i. Error in wavelength calibration.	Check calibration.
	j. Defective electronic component.	Refer to service manual or service center.
	k. Incorrect phototube or filter installed.	Check Table 2-2 (page 2-2) for correct phototube (SPECTRONIC® 20/20D only) and filter, and install.
5. Readings are not repeatable even though the 0%T and 100%T readings are set correctly.	a. Loose lamp.	Tighten thumbscrew on lamp access door.
	b. Loose sample holder adapter.	Tighten set screw inside adapter.
	c. Poor analytical technique.	Clean or replace dirty test tubes; remove bubbles, etc. See <i>Techniques</i> on page 2-2.
	d. Test tube position not repeating.	Always position fiducial line in exactly the same place when test tube is inserted into adapter. Use square cuvettes.
	e. Meter sticking (SPECTRONIC® 20 and 20* only).	Tap lightly for possible correction. If problem persists, refer to service center.

Section 4 - Accessories

Table 4-1 Accessories available for SPECTRONIC® 20 and 20 series of spectrophotometers*



<u>Accessory</u>	<u>Catalog Number</u>	<u>Description</u>
Cell Holders and Sample Compartment Adapters		See Table 4-2 on page 4-2.
SPECTRONIC® Standards	333150	Quick, reliable way to test and evaluate instrument performance: 0%T, wavelength accuracy, stray radiant energy, photometric accuracy; requires Cuvette Holder, Cat. No. 333176, and Adapter, Cat. No. 333178 (included with instrument)
Accessory Filter Kit	333129	Use for lowering stray light to $\leq 0.5\%T$ and for validating wavelength accuracy; includes four stray radiant energy / 2 nd order filters and one didymium filter
Accessory Printer	335488	
RS-232-C Serial Interface Cable	333177	Connects SPECTRONIC® 20D to Accessory Printer or computer
Vernier Software	333192-02	For using the SPECTRONIC® 20D or 20D* with an IBM-compatible computer; includes standard curve, wavelength scan and kinetics programs; see Table 2-1 on page 2-1 for required cable
RS-232C Cable	333132	Cable Kit to connect SPECTRONIC 20D or 20D* to an IBM-compatible computer, or SPECTRONIC 20D* to 335488 40-column printer
<i>SPECTRONIC® 20* Series Service Manual</i>	333182-10020	Includes optical diagrams, circuit diagrams, diagnostics, troubleshooting, schematics and assemblies
<i>SPECTRONIC® 20 Series Service Manual</i>	333175-10020	For SPECTRONIC® 20 and 20D models; includes optical diagrams, circuit diagrams, diagnostics, troubleshooting, schematics and assemblies
<i>Educational Manual</i>	332909-10030	Booklet of lab experiments and basic spectrophotometry information

Glassware selection and sampling options

In addition to the standard 1/2" test tube and 1/2" adapter supplied with the instrument, several types of glassware are available. The sample adapter must match the glassware, as shown in the chart below.

To change adapters, loosen the small set screw on the inner wall of the adapter using the adapter wrench clipped to the bottom of the instrument (see Figure 1-3).

Table 4-2 Cell selection chart for SPECTRONIC[®] 20^o series of spectrophotometers

PICTURE	DESCRIPTION	CATALOG NUMBER	PATHLENGTH	ADAPTER	ALSO REQUIRES:
	Square Cuvette Optical Glass 45 mm tall	331709	10 mm	333178 (included with instrument)	333176 Cell Holder
	Cuvette Optical Glass 100 mm tall	331701	11.66 mm	333178 (included with instrument)	—
	Semi-Micro Cuvette	331713	10 mm	333178 (included with instrument)	333176 Cell Holder (included with 331713 cuvettes)
	1/2" Test Tube Optical Glass 100 mm tall	331780	0.459" (11.7 mm)	333178 (included with instrument)	—
	3/4" Test Tube Optical Glass 150 mm tall	331781	0.657" (16.69 mm)	332931	332932 Light Shield
	1" Test Tube Optical Glass 150 mm tall	331782	0.880" (22.4 mm)	332930	332932 Light Shield

The design of the standard adapter provided with the instrument was changed in 1986. The current adapter (Cat. No. 333178) accommodates a 1/2" diameter test tube or a 1/2" square cuvette. Prior to 1986, the standard adapter (Cat. No. 333127) accommodated only the 1/2" diameter test tube.

To identify the standard adapter easily, turn the adapter bottom end up and look into the barrel of the adapter. Figure 4-1 illustrates the pre-1986 design which will not accommodate a 1/2" square cuvette. This can be replaced with a current adapter (Cat. No. 333178) to accommodate 1/2" square cuvettes.

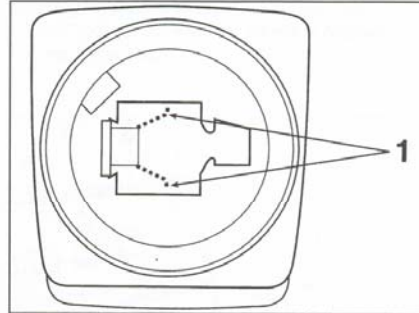

Figure 4-1 Standard adapter

KEY

1. Spring found in pre-1986 adapters

Appendix A - Choosing a Readout Mode

Transmittance Mode

All SPECTRONIC® 20* series spectrophotometers measure the relative amount of light transmitted, yielding results in transmittance. The transmittance mode is useful for calibration, stray radiant energy tests and filter studies. Furthermore, very low concentrations may be measured with greater sensitivity in the transmittance mode. When the transmittance mode is used, the reagent blank sets 100%T, and the results for standard solutions and unknown samples are obtained as percent transmittance.

A standard curve may be constructed on semi-logarithmic paper by plotting the percent transmittance on the logarithmic axis vs. the concentration of known standard solutions on the linear axis. The best line is drawn through these points. The concentration of unknown samples may then be determined by locating the concentration value which corresponds to the percent transmittance of the unknown on the standard curves.

Absorbance Mode

Usually, the operator desires results in absorbance for direct correlation of concentration by Beer's Law: $A=abc$. Results in percent transmittance may be converted to absorbance values by use of transmittance-absorbance conversion tables or by the formula $A=-\log_{10}T$. Results in absorbance may be plotted against the concentration of known standards on rectilinear graph paper. The best line is drawn through these points to construct a standard curve.

The concentration of unknowns may then be determined by locating on the standard curve the concentration value which corresponds to the absorbance of the unknown.

To eliminate %T to A calculations, each model of the instrument provides conversion of transmittance to absorbance:

- The SPECTRONIC® 20* has an absorbance scale marked with values corresponding to percent transmittance. The operator may simply read the absorbance scale and use these values to construct a standard curve as described above.
- The SPECTRONIC® 20D* offers precise electronic conversion of transmittance to absorbance. When the absorbance mode is used, the reference blank sets 0.000A, and the results for standards and unknowns are obtained in absorbance. Results in absorbance may be related to concentration by Beer's Law, $A=abc$, if the absorptivity and pathlength are known, or by constructions of a standard curve as described above.

Absorbance measurements are useful for kinetics studies and for reaction systems which do not obey Beer's Law and therefore have non-linear standard plots.

Concentration Mode

The SPECTRONIC® 20D* provides a more convenient readout, the concentration mode, which eliminates the necessity for constructing a standard curve. The instrument electronically converts results in absorbance to concentration units by multiplying the absorbance value by the factor which is the inverse of the slope of the standard curve (factor = $1/ab$).

Note that the concentration mode can be used only if the linearity of the standard curve has been verified for the test conditions used. These test conditions include wavelength, concentration range of interest, cuvette pathlength and analytical procedure. Furthermore, the concentration mode may be used only if the standard curve has a positive slope (i.e., absorbance increases with concentration).

When using entered standard solutions, the 1/ab factor is used to convert absorbance to concentration, according to the equation

$$C = f * A$$

Concentration Measurements using FACTOR mode on page 2-4 describes how to use the factor mode. For more information on concentration measurements and other techniques, contact Spectronic Instruments' Application Laboratory and request a list of available SpecTech Notes.

Note: It is not actually necessary to know the 1/ab factor because this factor is introduced into the instrument when the concentration adjust control is used to set the digital display to read the concentration of the standard. See page 2-4 for detailed instructions.

Concentration-Factor-Check Feature

To verify that operating conditions do not vary between reagent batches or from day to day, use the concentration-factor-check features as follows: After the concentration mode has been set up with standard solutions, press the MODE select control until the FACTOR LED lights, and read and record the factor given on the digital display. Every time new standard solutions are used for the same test (such as for a new reagent batch or when setting up the instrument), press the MODE select control until the FACTOR LED lights, and note the factor on the digital display.

A change in the factor indicates a change in the slope of the standard curve due to variation in operating conditions. It is recommended that a standard always be used to set the concentration mode. The operator may choose, however, to set the blank to 000A, then switch to the concentration mode.

Appendix B - Optical Diagram

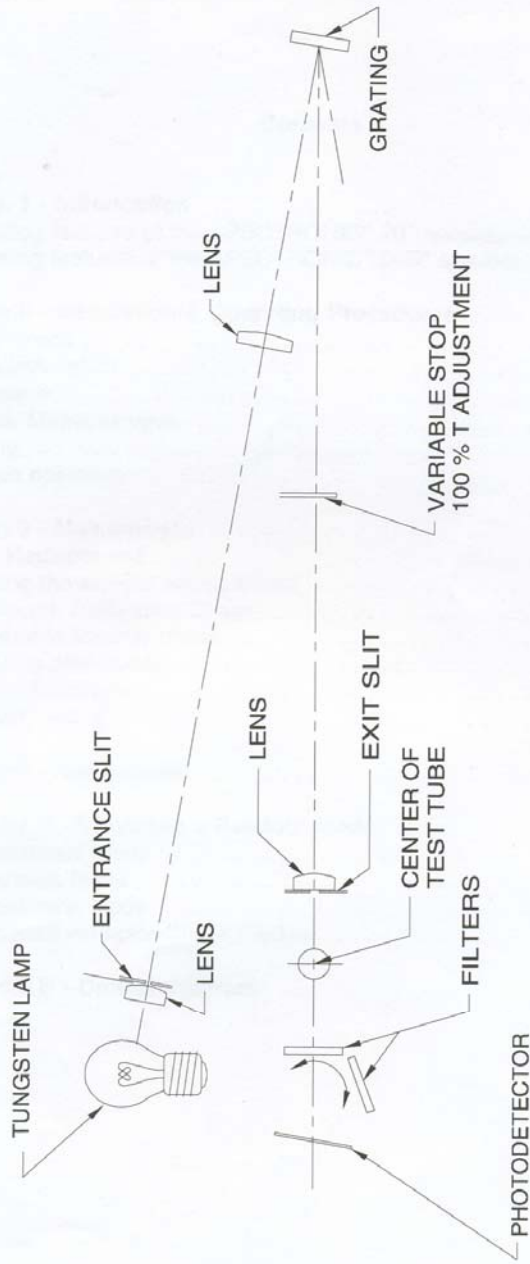

Figure B-1 Optical diagram for SPECTRONIC® 20+ series spectrophotometers





820 Linden Avenue, Rochester, NY 14625, USA
Telephone: (800) 654-9955 or (716) 248-4000 / Facsimile: (716) 248-4014

Life Sciences International (Europe) Ltd., 93/96 Chadwick Road, Astmoor Industrial Estate, Runcorn, Cheshire, WA7 IPR, England
Telephone: Int + 44-1928-566611 / Facsimile: Int + 44-1928-565845

Spectronic Instruments (Hong Kong) Ltd., Room 508-509, Kornhill Metro Tower, 1 Kornhill Road, Quarry Bay, Hong Kong
Telephone: Int + 852-28854613 / Facsimile: Int + 852-25674447

LabSystems Japan K.K. Esuporawu 21, 130-16, Yamabuki-cho, Shinjuku-ku, Tokyo 162, Japan
Telephone: Int + 81-3-5261-0231 / Facsimile: Int + 81-3-5261-0230