

TSD104A BLOOD PRESSURE TRANSDUCER

The TSD104A measures direct arterial or venous blood pressure in animals or records pressure changes within an in-vitro circuit (e.g. Langendorff heart preparation). The TSD104A connects to tubing via standard Luer Lok fittings. The transducer is small and lightweight and the slotted base, with integral Velcro strap, permits easy mounting. The TSD104A interfaces with the DA100C general-purpose transducer amplifier. The transducer is supplied non-sterile but can be sterilized using ethylene oxide (ETO) gas. TSD104A includes the transducer with sensor element; replacement sensors (RX104A) can be purchased without the cable, making this a very economical solution for pressure sensing applications.



TSD104A



TSD104A-MRI

TSD104A-MRI BLOOD PRESSURE TRANSDUCER FOR MRI

Use this blood pressure transducer for general arterial pressure studies in the MRI.

The TSD104A-MRI terminates in a DSUB9 connector and requires the [MECMRI-DA](#) cable/filter interface to DA100C.

MRI Usage: MR Conditional to 7T

Condition: Conductive parts are electrically and thermally isolated from subject. For animal use only when using direct to catheter blood pressure measurement.

RX104A REPLACEMENT ELEMENT

The RX104A is a replacement element for the TSD104A or SS13L blood pressure transducer; it does not include the TCI connector and cable.

RX104A-MRI REPLACEMENT ELEMENT

RX104A-MRI is the replacement pressure-sensing element for blood pressure transducer TSD104A-MRI; it does not include the connector and cable.



MRI Usage: MR Conditional to 7T

Condition: Animal use only

TSD104A/TSD104A-MRI Specifications

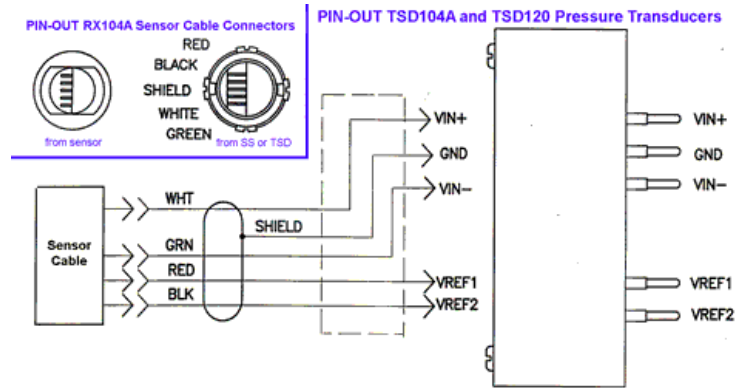

| | |
|---|--|
| Operational pressure: | -50 mmHg to +300 mmHg |
| Overpressure: | -400 mmHg to +4,000 mmHg |
| Dynamic Response: | 100 Hz |
| Unbalance: | 50 mmHg max |
| Connection Ports: | Male Luer and female Luer (sensors shipped prior to summer 2010 were male Luer on both sides) |
| Eight-hour Drift: | 1mmHg after 5 minute warm-up |
| Isolation: | ≤ 5 μA leakage at 120 VAC/60 Hz |
| Defibrillation: | Withstands 5 discharges of 400 joules in 5 minutes across a load |
| Operating temperature: | +15° C to +40° C |
| Storage Temperature: | -30° C to +60° C |
| Temperature Coefficient: | ± 0.4 mmHg / deg C |
| Combined effects of sensitivity, linearity, and hysteresis: | 1 mmHg (nominal) |
| Output: | 5 μV/mmHg (normalized to 2 V excitation) |
| Weight: | 11.5 grams |
| Transducer Dimensions: | 67mm long x 25mm wide |
| Cable length: | TSD104A 3 meters TSD104A-MRI 8 meters RX104A No cable |
| Interface: | TSD104A DA100C TSD104A-MRI MECMRI-DA to DA100C |

TSD104A Calibration

See DA100C Calibration options.